

SPEED X PRECISION

Over Forty Years of Legendary Reliability Magnescale counter history

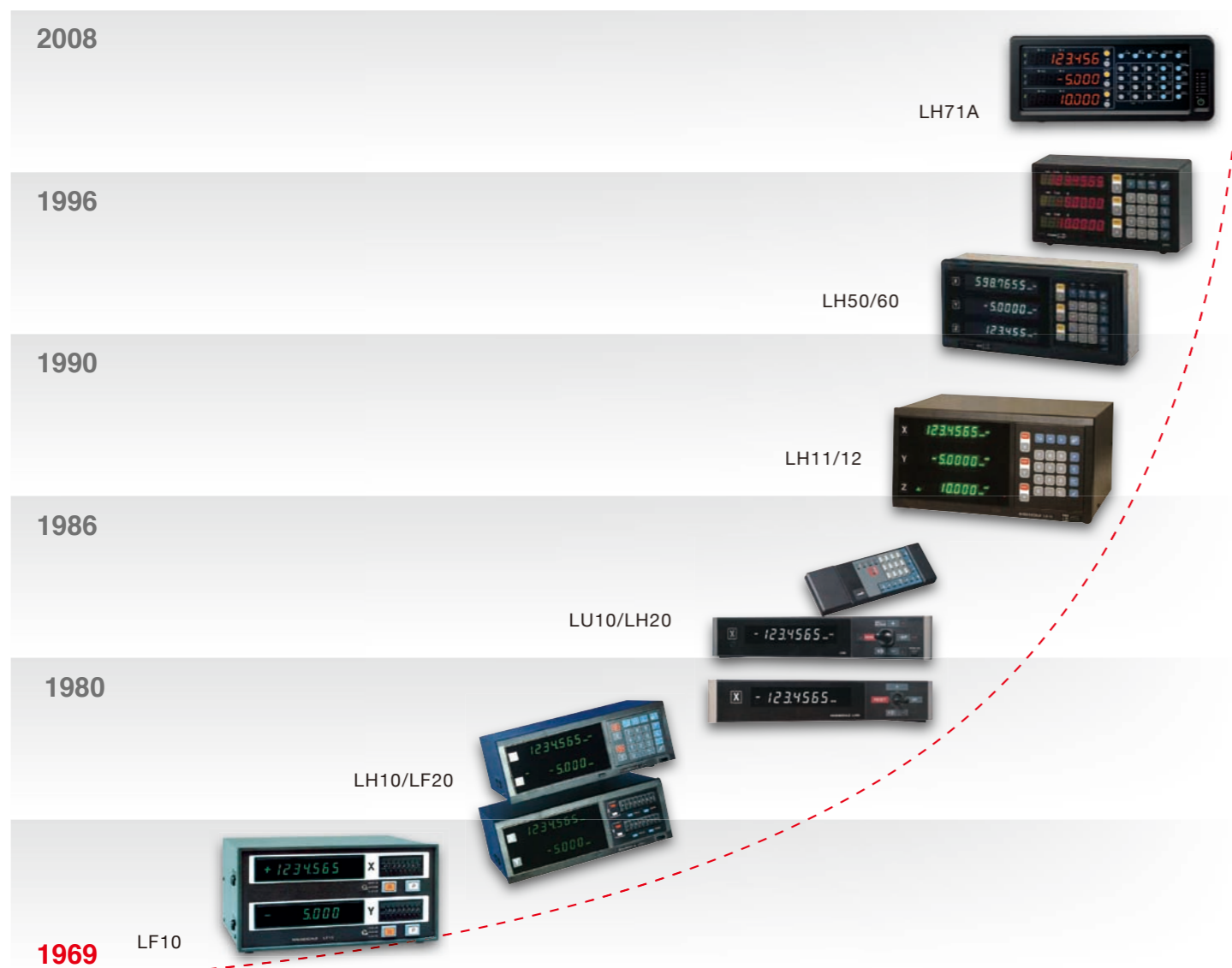

Some old models may require adapter or other accessories. If you have any question, please contact us.

Magnescale Co., Ltd.

Shinagawa Intercity Tower A-18F, 2-15-1, Konan, Minato-ku, Tokyo 108-6018, JAPAN
 Headquarters : 45 Suzukawa, Isehara-shi, Kanagawa 259-1146, JAPAN
 Tokyo Office : Shinagawa Intercity Tower A-18F, 2-15-1, Konan, Minato-ku, Tokyo 108-6018, JAPAN
 Nagoya Office : 2-35-16, Meieki, Nakamura-ku, Nagoya Aichi, 450-0002, JAPAN
 Osaka Office : 2-14-6, Nishi-Nakajima, Yodogawa-ku, Osaka 532-0011, JAPAN
 International Sales Department : 45 Suzukawa, Isehara-shi, Kanagawa 259-1146, JAPAN
 Magnescale Americas Inc. : 5740 Warland Drive, Cypress, CA 90630, USA
 Magnescale Europe GmbH : Antoniusstrasse 14, 73249 Wernau, Germany

TEL.+81(0)463-92-1011 FAX.+81(0)463-92-1012
 TEL.+81(0)3-5460-3574 FAX.+81(0)3-5460-9614 E-mail : info-tokyo@magnescale.com
 TEL.+81(0)52-587-1823 FAX.+81(0)52-587-1848 E-mail : info-nagoya@magnescale.com
 TEL.+81(0)6-6305-3101 FAX.+81(0)6-6304-6586 E-mail : info-osaka@magnescale.com
 TEL.+81(0)463-92-7971 FAX.+81(0)463-92-7978 E-mail : info-mgs-eng@magnescale.com
 TEL.+1(562)594-5060 FAX.+1(562)594-5061 E-mail : info-am@magnescale.com
 TEL.+49(0) 7153 934 291 FAX.+49(0) 7153 934 299 E-mail : info-eu@magnescale.com

<http://www.magnescale.com>

The contents of this literature are as of Jan. 2013
 This catalog is printed with soy ink.
 MGS-DR-1301-EN-C

For more information, please visit our website.



Digital Readout

Magnescale Co., Ltd.

**For over 40 years,
Magnescale has been providing
superior accuracy and
legendary reliability to
customers around the world.**

Magnescale magnetic scale technology can maintain high accuracy even under the harsh environments without being affected by condensation, oil or coolant.

With a wide range of capability and installation options, Magnescale magnetic scale technology is suitable for all types of machines.

The Advantages of Magnetic Scales:

- Resistant to oil, dust, vibration and shock
- Easy installation

Suitable for a wide range of applications:

- Grinding machines
- Milling machines
- Measuring machines
- Lathes
- Drilling machines
- Measuring fixtures

Digital Readouts



Multifunctional counters LG20, LH70, LH71, LH71A, LH72

The LH70 Series are position counters developed for general-purpose machine tools. LH71A-3 can be used for milling machines and lathes applications by switching initial settings. LH72 is designed for lathes.

Multifunction units LG20 / LH70/71/72 series				
	LG20	LH70	LH71 / LH71A	LH72
Display axes	1, 2, 3			3
Display	7 digits, orange LEDs, floating minus sign			
Display resolution	0.1/0.5/1/5/10 μm	0.1/0.5/1/5/10 μm 1 s /10 s/ 1 min/10 min		
Input signal	A/B quadrature/Z signal (EIA422)			
Compatible measuring systems	GB-ER, SJ700A and PL20C with SL110 / 130			
Power supply	12 VDC using separate power supply unit PSC2* with 100-240 VAC			
Weight	1.5 kg			

Functions at a glance

Model	LG20	LH70	LH71	LH71A	LH72
Reset	■	■	■	■	■
Preset	■	■	■	■	■
Absolute/Incremental		■	■	■	■
Diameter display	■	■	■	■	■
Angle display		■	■	■	■
Alarm display	■	■	■	■	■
Zero point detection		■	■	■	■
Datum points		10	150	150	
Tool memory*		12	99	99	99
Midpoint calculation		■	■	■	■
Scaling			■	■	■
Addition function*		■	■	■	■
Programming function			■	■	■
Bolt hole circle		■	■	■	
Line hole			■	■	
Simple R cutting		■	■	■	
Linear error compensation	■	■	■	■	■
Segment error compensation			■	■	■
Data storage	■	■	■	■	■
Energy saving function	■	■	■	■	■
Navigation function		■	■	■	■
External reset				■	■
Touch sensor function				■	

* only 3 axis display

GB-ER

Renowned for its legendary accuracy and reliability, the GB-ER is suitable for precise, high-resolution applications.

- Excellent durability against workshop conditions - resistant to oil, dirt, shock and vibration
- Compact design for easy installation
- Resolution: 0.5 μm
- Accuracy: (5+5L/1000) μm



GB Series Connection Chart

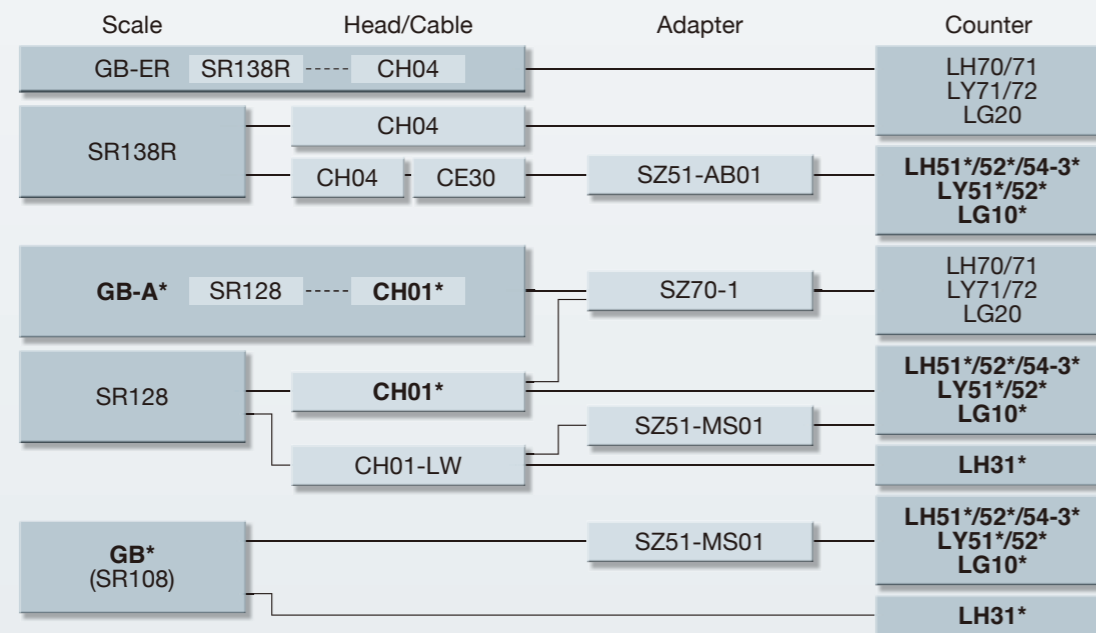

Products marked * are discontinued

SJ700A

Reliable magnetic scale general purpose applications

- Same coefficient of expansion as machine tools
- Measuring length: 150 mm to 1600 mm / 5.9" to 62.9"
- Resolution: 5 μm
- Accuracy: $\pm 10 \mu\text{m}$, $\pm 15 \mu\text{m}$
- Output signal: A/B Quadrature



SL110/130

Digiruler is a non-contact, flexible magnetic tape scale. This design creates unparalleled durability and easy installation for all types of measurement applications.

- Available in lengths up to 30 m (SL130)
- Cost efficient for applications from woodworking to metal cutting
- Resolution: 10 μm (with PL20C)
- Max. response speed: 300 m/min (with PL20C)

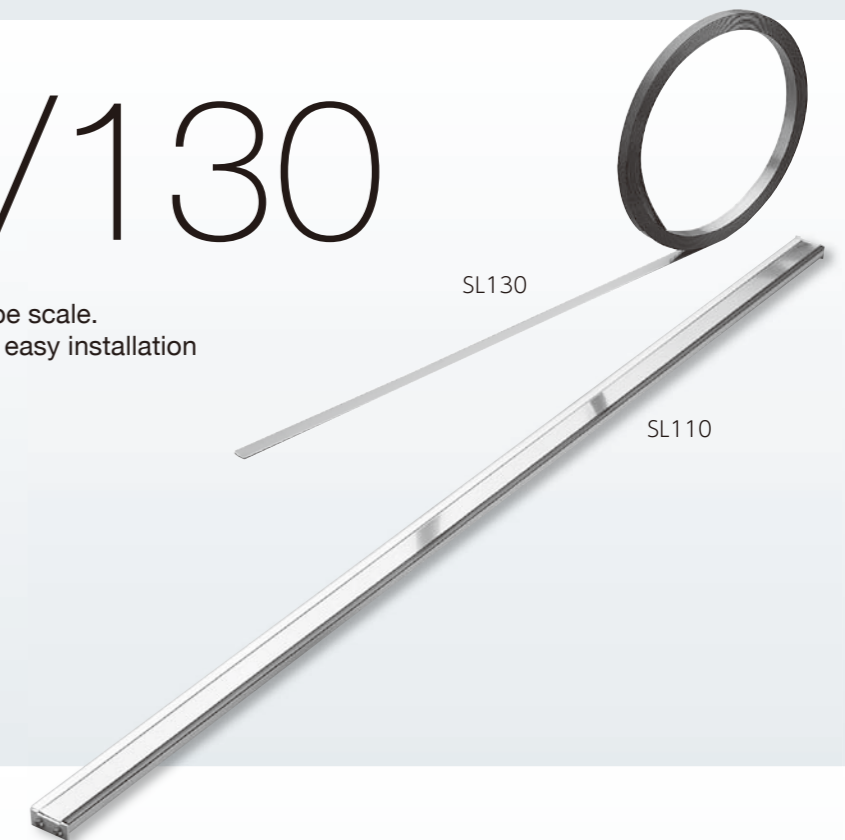

PL20C

Reader Head and Cable (for SL110/SL130)

- Excellent resistance to workshop conditions (IP65)
- Resistant to oil, dirt, vibration, and shock
- Resolution: 10 μm (with PL20C)
- Max. response speed: 300 m/min (varies with the read head and settings)
- Output signal: A/B quadrature (with PL20C)



GB-ER

Specifications		GB-ER
Model	GB-ER	
Measurement Length (ML) L: mm(inch)	50 (1.9"), 100 (3.9"), 150 (5.9"), 200 (7.8"), 250 (9.8"), 300 (11.8"), 350 (13.7"), 400 (15.7"), 450 (17.7"), 500 (19.6"), 550 (21.6"), 600 (23.6"), 650 (25.5"), 750 (29.5"), 850 (33.4"), 950 (37.4"), 1050 (41.3"), 1250 (49.2"), 1400 (55.1"), 1600 (62.9"), 1850 (72.8"), 2050 (80.7"), 2200 (88.6")	
Overall length	Measuring length + 104 (4.1(50 to 200 mm)*) Measuring length + 120 (4.7(250 to 2200 mm)*)	
Max. travel	L + 14 mm (50 to 200 mm) Overall length (250 to 2200 mm) L + 30 mm (250 to 2200 mm) Overall length (50 to 200 mm)	
With or without Centerfootplate	Included with ML: 1050 mm to 2200 mm Excluded ML: 50 mm to 950 mm	
Accuracy at 20 °C/68 °F	(5 + 5L / 1000) μm	
Resolution	0.5 μm	
Max. response speed (scale signal, reference signal)	60 m/min	
Reference point	Standard:Center of scale, User-defined position also available	
Mounting parallelism	± 0.1 mm	
Thermal expansion coefficient	(11±1) × 10 ⁻⁶ /°C	
Operating temperature	0 °C to 40 °C/ 32 °F to 104 °F	
Storage temperature	-20 °C to 50 °C/ 4 °F to 122 °F	
Head cable length	0.3 m	
Cable length	3 m	
Protective design grade	Scale: IP65 (Interpolation Unit: IP30)	
Input/Output signal	Output signal	AB/ quadrature signal, Z signal
	Power supply	+5 VDC ±5 %
Power consumption	Connector	D-sub 9 pin
		Max. 200 mA

SJ700A

Specifications		SJ700A
Model	SJ700A	
Measurement Length (ML) L: mm(inch)	150 (5.9"), 250 (9.8"), 350 (13.7"), 400 (15.7"), 500 (19.6"), 650 (25.5"), 800 (31.5"), 950 (37.4"), 1050 (41.3"), 1250 (49.2"), 1400 (55.1"), 1600 (62.9")	
Overall length	Measuring length + 120 (4.73")	
Max. travel	Measuring length + 20 (0.78") (10 (0.39") each at right and left)	
With or without Centerfootplate	Included with ML: 1250 mm to 1600 mm Excluded ML: 150 mm to 1050 mm	
Accuracy at 20 °C/68 °F	±10 μm (Measuring length 1250 (49.21") or less) ±15 μm (Measuring length 1400 (55.12") or more)	
Resolution	5 μm	
Thermal expansion coefficient	(12 ±1) × 10 ⁻⁶ /°C	
Operating temperature	0 °C to 40 °C/ 32 °F to 104 °F	
Storage temperature	-20 °C to 60 °C/ 4 °F to 140 °F	
Protective design grade	IP54	
Input/Output signal	Output signal	AB/ quadrature signal, Z signal
	Power supply	+5 VDC ±5 %
Power consumption	Connector	D-sub 9 pin
		Max. 200 mA

SL110/SL130

Model	SL110		SL130	
	-20 to -200	-20 to -700	-800 to -3000	
Measurement length L mm (inch)	200/300/400/500/600/700/800/1000/1200/ 1500/1600/1700/1800/2000 (7.8/11.8/15.7/19.6/23.6/27.5/31.4/39.3/47.2/ 59.0/62.9/66.9/70.8/78.7)	200/300/400/500/600/700/800/1000/1200/ 1500/1600/1700/1800/2000/2500/3000/ 4000/5000/6000/7000 (7.8/11.8/15.7/19.6/23.6/27.5/31.4/39.3/ 47.2/59.0/62.9/66.9/70.8/78.7/98.4/118.1/ 157.4/196.8/236.2/275.5)	8000/9000/10000/20000/30000 (314.9/354.3/393.7/787.4/1181.1)	
Overall length	L+103 mm/ 4.1"		L+100 mm/ 3.9"	
Accuracy at 20 °C/68 °F	± (25 + 5L/ 1000) μm		± (25 + 5L/ 1000 + 10N) μm N=1 when L=8000 /9000/10000, N=2 when L=20000, N=3 when L=30000	
Resolution	10 μm			
Max. response speed	300 m/min			
Thermal expansion coefficient	(11.1 ± 1) × 10 ⁻⁶ /°C		(10.4 ± 1) × 10 ⁻⁶ /°C	
Operating temperature	-5 °C to 45 °C / 23 °F to 113 °F			
Storage temperature	-10 °C to 50 °C / 14 °F to 122 °F			
Compatible read head	PL20C			

*Accuracy shows the value when used with PL20C read head.

PL20C

Specifications						
Model	PL20C-3/-3C	PL20C-5/-5C	PL20C-10/-10C	PL20C-15/-15C	PL20C-20/-20C	PL20C-30
Cable length	3 m	5 m	10 m	15 m	20 m	30 m
Output signal	AB quadrature signal					
Resolution	10 μm					
Max. response speed	300 m/min					
Head mtg. screw tightening torque	0.7-1.1 N·m					
Operating temperature	0 °C to 45 °C/32 °F to 113 °F					
Storage temperature	-10 °C to 50 °C/-14 °F to 122 °F					

Accessories

Power supply adapter

- PSC-21 (For Japan only) 100 V
- PSC-22 (For U.S. only) 120 V
- PSC-23 (For Europe and other country.) 220 to 240 V

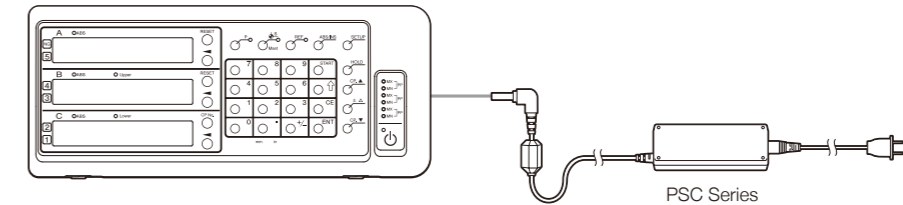

System configuration

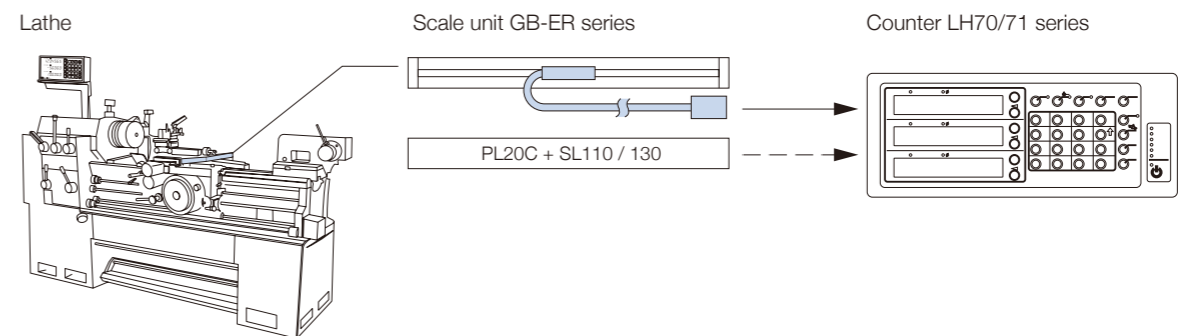
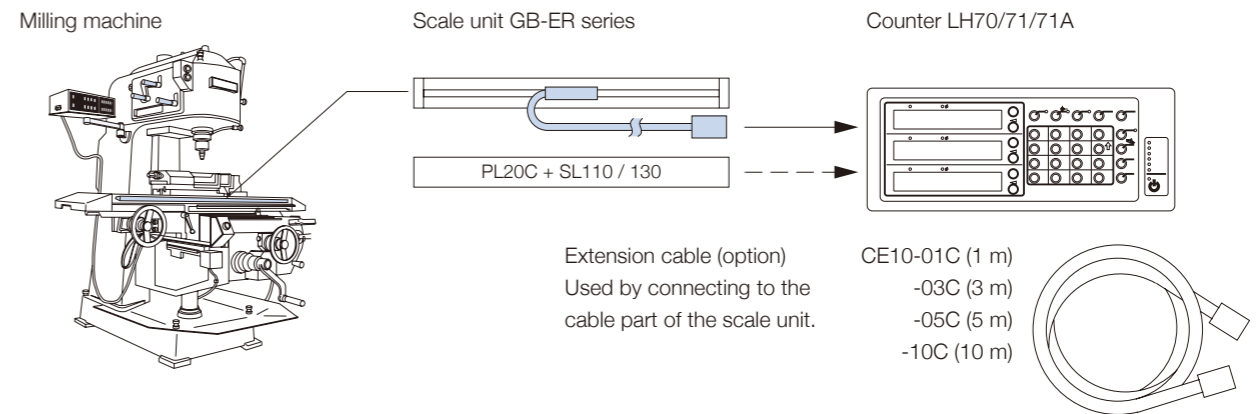

How to order

LG20 - □	PSC-21	GB - □□□ ER	SJ700A - □□□
LH70 - □	-22	Series L of scales in cm	Series L in cm
LH71 - □	-23		
LH71A - □	Separate power supply		
Series			
	Number of axes (1, 2 or 3)		
SL110 - □□□ + PL20C - □ C			
Series	L in cm	Series	Length of connecting cable (m)
			With armour